

BLAST CABINETS

CAB-series

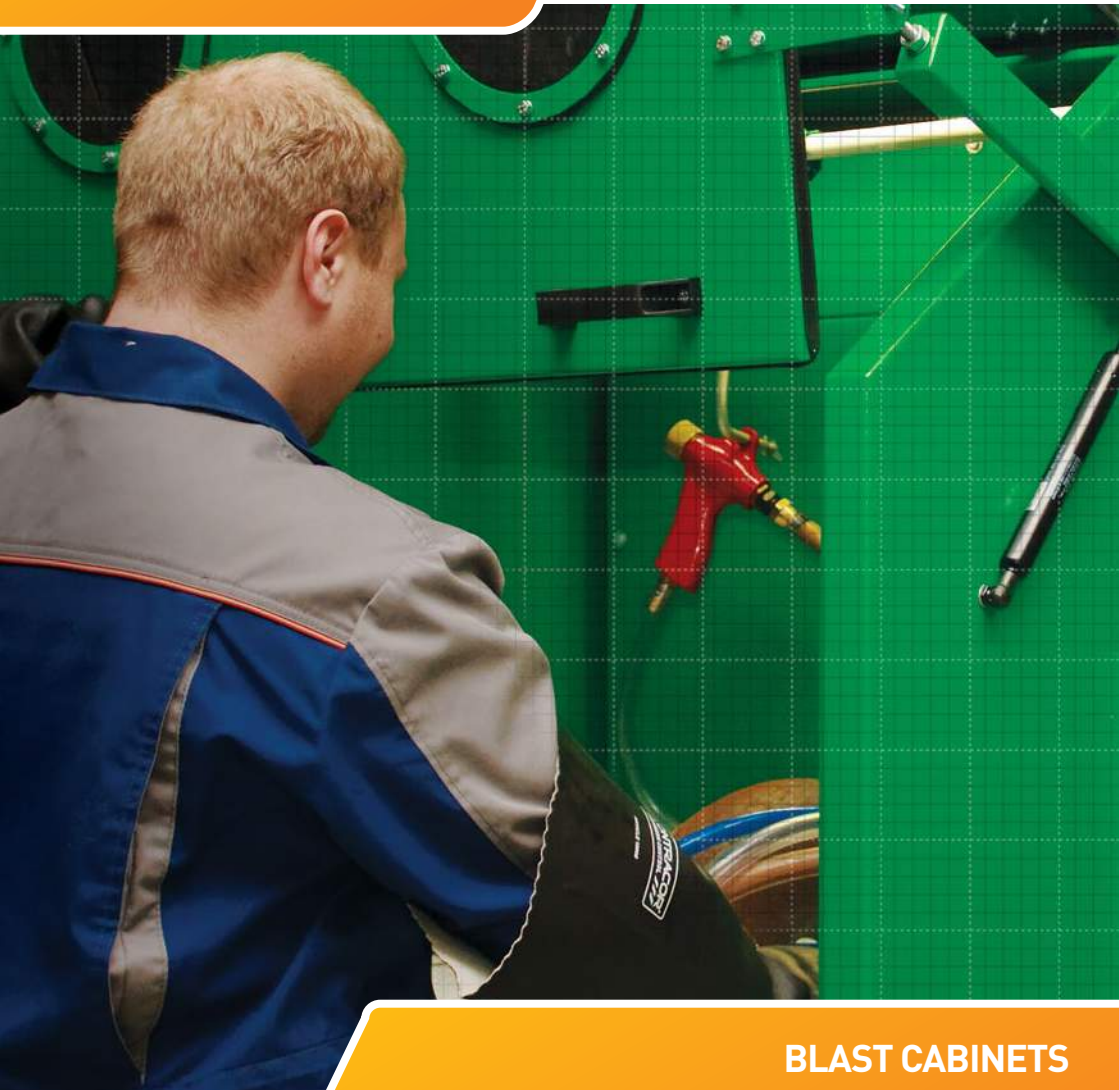

BLAST CABINETS CAB-series

Economy models, for long lasting light and medium industrial use. Frontal loading or loading from above by crane. Space efficient and flexible due to use of a freestanding dust collector. For operation with fine or light abrasives. Blast cabinet is manufactured in accordance with European CE regulations, and fulfills specifications concerning operator safety and filtration of technological air.



BLAST CABINETS CAB-series

Professional models, for medium duty long lasting industrial use. Heavy-duty all-welded steel construction. Loading through extra-wide door on each side. Large dimensioned cyclone reclaimer for blast media cleaning. Powerful dust collector for working with heavyweight blast media. Blast cabinet is manufactured in accordance with European CE regulations and fulfills regulations concerning operator safety and filtration of technological air.

CAB-series suction blast cabinets

Industrial use all-in-one blast cabinet includes injection blast system, blast media reclaimer and pulse cleaned cartridge dust collector.

FIELD OF APPLICATION

Abrasive blasting applications including cleaning, deburring, deflashing, finishing, peening and decorating.

Build for long lasting industrial use for operation with fine or light abrasives.

Advantages

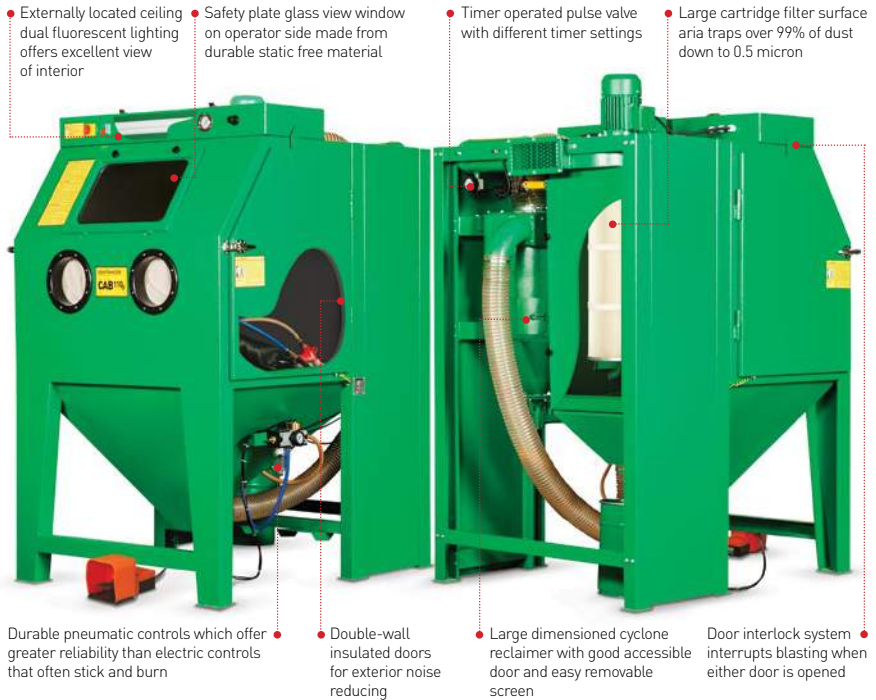
- 
- Externally located ceiling dual fluorescent lighting offers excellent view of interior
 - Safety plate glass view window on operator side made from durable static free material
 - Timer operated pulse valve with different timer settings
 - Large cartridge filter surface area traps over 99% of dust down to 0.5 micron
 - Durable pneumatic controls which offer greater reliability than electric controls that often stick and burn
 - Double-wall insulated doors for exterior noise reducing
 - Large dimensioned cyclone reclaimer with good accessible door and easy removable screen
 - Door interlock system interrupts blasting when either door is opened

Designed to work with

Aluminum oxide, silicon carbide, garnet, glass beads, steel grit and steel shot, plastic abrasives.

CAB-110S, CAB-135S - suction type blast cabinets



Standard delivery

All-welded blast cabinet, ready to use assembled with media recovery hoses, abrasive metering valve, transparent media delivery hose, air hose, GX manual blast gun with GXT-8 tungsten carbide nozzle, lined rubber gloves RGS-800, pilot operated control valve, foot valve with remote control hoses, air filter with manual drain valve, cartridge dust filter, timer operated pulse jet cleaning system, safety and disposable glass window assembly.

Technical data	CAB-110S	CAB-135S
Interior Dimensions D x W x H, mm	1100x800x840	1350x1100x1070
Overall Dimensions D x W x H, mm	1220x1340x1990	1470x1700x2140
Door Opening W x H, mm	690x840	1000x1000
Dust collector, type	DC-1100	DC-1500
Cyclone reclaim, type	R-350	R-400
Filter area (polyester), m ²	7,5	11,0
Filter cartridge pulse jet cleaned	yes	yes
Electrical connection, kW	1,20 kW, 380V~	1,60 kW, 380V~
Standard load capacity, kg	350	350

Order code	Model	Description
10215105	CAB-110S	Suction type blast cabinet, standard delivery
10215106	CAB-135S	Suction type blast cabinet, standard delivery

CAB-110SD, CAB-135SD - suction type blast cabinets

Additional features



SD special model

Professional models with increased functionality.

Special models SD are equipped with pass-through cabin doors on each side and are fitted with rubber curtains. Pass-through cabinet doors for blast cleaning of long-length parts. Pass size 350 x 350 mm. Equipped with a damper plate and a rubber shield.

Additional to the standard delivery

Special model SD	CAB-110SD	CAB-135SD
Pass-through cabinet doors, left/right	yes	yes
Pass size, mm	350x350	350x350
Standard load capacity, kg	350	350

Order code	Model	Description
10215109	CAB-110SD	Suction blast cabinet, special model SD - pass-through cabinet doors and rubber curtains
10215110	CAB-135SD	Suction blast cabinet, special model SD - pass-through cabinet doors and rubber curtains

CAB-110ST, CAB-135ST – suction type blast cabinets



ST special model

Additional features

• Rubber curtains

• Turntable with cart and tracks



Professional models for medium duty long lasting industrial use.

Heavy or awkward parts are more easily moved inside a blast cabinet with a turntable. The turntable provides safe and convenient blasting access and can increase productivity significantly. Special models ST are equipped with a turntable TTM-500 / TTM-800 with cart and tracks and are fitted with rubber curtains on cabinet internal walls.

Additional to the standard delivery

Special model ST	CAB-110ST	CAB-135ST
Turntable type	TTM-500-110	TTM-800-135
Turntable diameter, mm	500	800
Cabinet overall dimensions with installed trucks D x W x H, mm	2950x1340x1990	3680x1700x2140
Standard load capacity, kg	350	350

Order code	Model	Description
10215111	CAB-110ST	Suction blast cabinet, special model ST – turntable with cart and tracks and rubber curtains
10215112	CAB-135ST	Suction blast cabinet, special model ST – turntable with cart and tracks and rubber curtains

CAB-series pressure blast cabinets

Industrial use all-in-one blast cabinet includes direct pressure blast system, blast media reclaimer and pulse cleaned cartridge dust collector.

FIELD OF APPLICATION

Abrasive blasting applications including cleaning, deburring, deflashing, finishing, peening and decorating. Built for long lasting industrial use for high performance operation with all types of abrasives.

Advantages

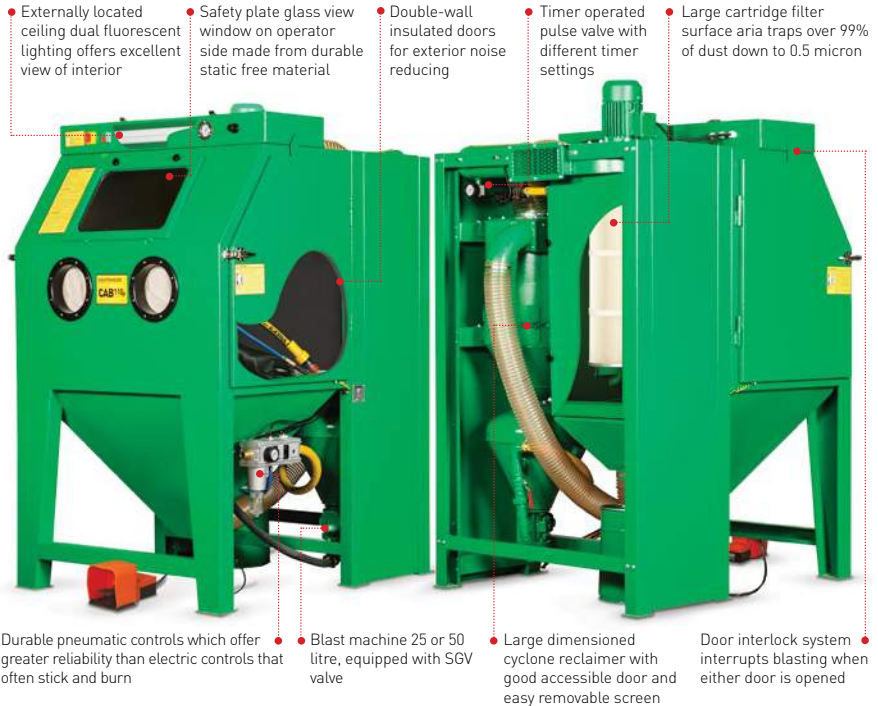

Designed to work with

Aluminum oxide, silicon carbide, garnet, glass beads, steel grit and steel shot, plastic abrasives.

CAB-110P, CAB-135P – pressure type blast cabinets



Standard delivery

All-welded blast cabinet, ready to use assembled with 25 or 50 liter blast machine, media recovery hoses, sandblast hose ExtraBlast-19, nylon hose coupling CQP-3/4, nylon nozzle holder NHP 3/4, STC-6,5 tungsten carbide nozzle, lined rubber gloves RGS-800, pilot operated control valve, foot valve with remote control hoses, air filter with manual drain valve, cartridge dust filter, timer operated pulse valve, safety and disposable glass window assembly.

Technical data	CAB-110P	CAB-135P
Interior Dimensions D x W x H, mm	1100x800x840	1350x1100x1070
Overall Dimensions D x W x H, mm	1220x1340x1990	1470x1700x2140
Door Opening W x H, mm	690x840	1000x1000
Blast machine type	CBS-25	CBS-25
Dust collector, type	DC-1100	DC-1500
Cyclone reclaim, type	R-350	R-400
Filter area (polyester), m ²	7,5	11,0
Filter cartridge pulse jet cleaned	yes	yes
Electrical connection, kW	1,20 kW, 380V~	1,60 kW, 380V~
Standard load capacity, kg	350	350

Order code	Model	Description
10215205	CAB-110P	Pressure type blast cabinet, standard delivery
10215206	CAB-135P	Pressure type blast cabinet, standard delivery

CAB-110PD, CAB-135PD – pressure type blast cabinets

Additional features



• Pass-through cabinet doors



• Rubber curtains



PD special model

Professional models with increased functionality.

Special models PD are equipped with pass-through cabinet doors on each side and are fitted with rubber curtains on cabinet internal walls. Pass-through cabinet doors for blast cleaning of long-objects. Pass size 350 x 350 mm. Equipped with a damper plate and a rubber shield.

Additional to the standard delivery

Special model PD	CAB-110PD	CAB-135PD
Pass-through cabinet doors, left/right	yes	yes
Pass size, mm	350x350	350x350
Standard load capacity, kg	350	350

Order code	Model	Description
10215209	CAB-110PD	Pressure blast cabinet, special model PD - pass-through cabinet doors and rubber curtains
10215210	CAB-135PD	Pressure blast cabinet, special model PD - pass-through cabinet doors and rubber curtains

CAB-110PT, CAB-135PT – pressure type blast cabinets



Additional features

• Rubber curtains

• Turntable with cart and tracks



PT special model

Professional models for medium duty long lasting industrial use.

Heavy or awkward parts are more easily moved inside a blast cabinet with a turntable. The turntable provides safe and convenient blasting access and can increase productivity significantly. Special models PT are equipped with a turntable TTM-500 / TTM-800 with cart and tracks and are fitted with rubber curtains on cabinet internal walls.

Additional to the standard delivery

Special model PT	CAB-110PT	CAB-135PT
Turntable type	TTM-500-110	TTM-800-135
Turntable diameter, mm	500	800
Cabinet overall dimensions with installed trucks D x W x H, mm	2950x1340x1990	3680x1700x2140
Standard load capacity, kg	350	350

Order code	Model	Description
10215211	CAB-110PT	Pressure blast cabinet, special model PT – turntable with cart and tracks and rubber curtains
10215212	CAB-135PT	Pressure blast cabinet, special model PT – turntable with cart and tracks and rubber curtains

Blast cabinets CAB-series overall dimensions

Suction blast cabinets

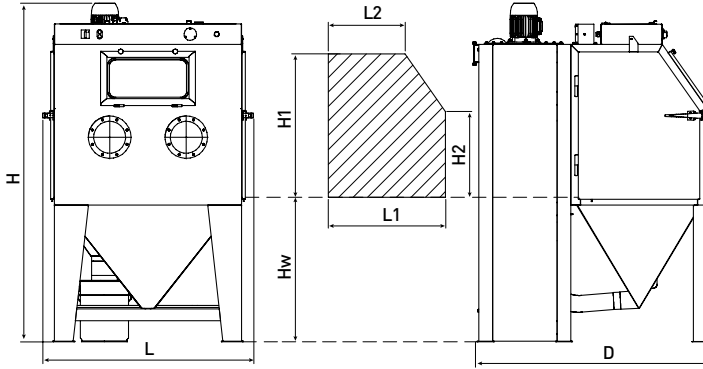

Model	H (mm)	Hw (mm)	H1 (mm)	H2 (mm)	L (mm)	L1 (mm)	L2 (mm)	D (mm)
CAB-110S	1990	849	840	502	1240	688	450	1390
CAB-135S	2160	847	1000	502	1490	988	645	1770

Pressure blast cabinets

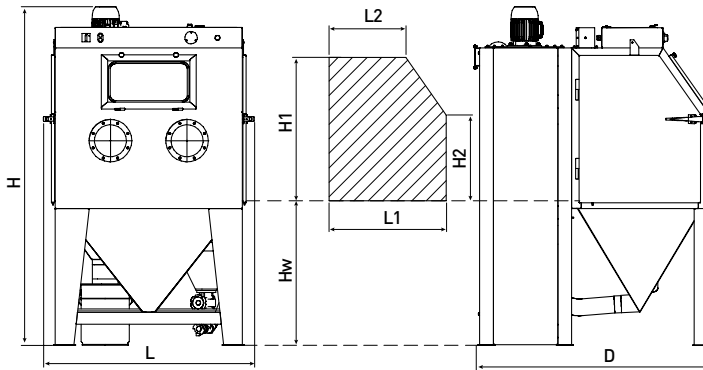

Model	H (mm)	Hw (mm)	H1 (mm)	H2 (mm)	L (mm)	L1 (mm)	L2 (mm)	D (mm)
CAB-110P	1990	849	840	502	1240	688	450	1390
CAB-135P	2160	847	1000	502	1490	988	645	1770

Turnables with cart and tracks overall dimensions

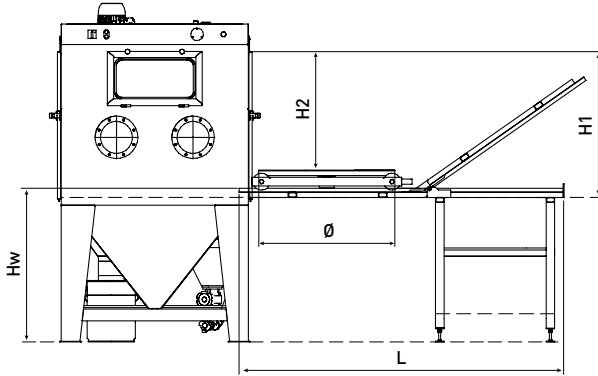

Model	Ø (mm)	Hw (mm)	H1 (mm)	H2 (mm)	L (mm)
TTM-500-110	500	890 - 934	840	680	1910
TTM-500-135	500	890 - 934	1000	840	2205
TTM-800-135	800	890 - 934	1000	840	2205

